



DSSA provide fully customised keypads to fit our customer's design and functionality requirements. Our extensive range of standard keypads allows a designer to build a semi-custom system for minimal cost.

The NEW POWERKEY ULTIMATE 1200MI reconfigurable keypad provides hassle free control and customisation literally at your fingertips. The PKU1200MI is easily reconfigurable, readdressable and relegendable.

Requiring only a laptop or PC connection for reprogramming.

Its secure locking inserts can easily be interchanged to match the new configuration.

STANDARD FEATURES:

- Brighter LED's
- LED Backlit Icons
- Sealed IP68
- CRM, Designer, ECS Firmware Options
- Optional Inserts



FLEXIBLE - SMART - RUGGERED

 **CANopen / J1939 / NMEA 2000**

WWW.DIGITALSWITCHING.COM.AU

SALES@DIGITALSWITCHING.COM.AU

STANDARD FEATURES

- Supply voltage 12-24v
- Relegendable buttons
- Multicolour indicator rings
- Vertical or horizontal mount
- Improved thermal dissipation
- Full colour LED indicators - including pure white
- Standard and custom legends
- Added overload feedback on output drives to detect short circuit or over current events
- Significant power reductions - PKU mini consumes with all LED's active 70 mA @12v
- Simplified CAN messaging using our CANconnect software to control multiple LED's within a single message

DESIGNER FIRMWARE FEATURES

- 256 step brightness control for each colour
- New LED effects (blink, pulse, spin, ripple, split)
- ON/OFF, momentary, toggle, scroll/step functions programmable for each key
- Autonomous operation (key press causes LED to change state without feedback from external device)
- NMEA 2000 bus compliant (support ISO requests, address claim, binary status 127501 and binary control 127502 messages)

PROTOCOLS & ACCESSORIES

- Free Software Utility
- Connector Options Include: Deutsch, Molex & more

MECHANICAL

Connector	Deutsch DT04-4P, Molex 19418-0004, Micro-C
Switch Life	3 Million Operations
Mechanical Shock	X, Y, Z 50Gs 11ms
Vibration	X, Y, Z 10 - 150Hz 0.15mm amp
Mounting Studs	#10-32 CDS-510 phosphor bronze, electroplated bright tin
Keypad	Silicone rubber with polyurethane hardcoat

ENVIRONMENTAL

Operating Temperature	-40°C to +85°C
Storage Temperature	-40°C to +85°C
Thermal Shock	-40° to +72°C @4°C/Min
Humidity	0 to 98% (No Condensation)
UV Protection / Salt Spray	UVB 400 hours / Per ASTM B117
Chemical Resistance	EET, Engine Cleaner, Isopropyl Alcohol, Suntan Lotion, Multi-Purpose Cleaner, Orange Citrus Cleaner
Ingress Protection Rating	IP68 / NEMA 6

ELECTRICAL

Supply Voltage	12-24V Nominal 8-32V
Standby Current	<50mA
Communication Bus	CANopen or J1939

OTHER FEATURES

Size MM	104.65 x 39.62 x 20.71
Weight	97.65g

DIMENSIONS

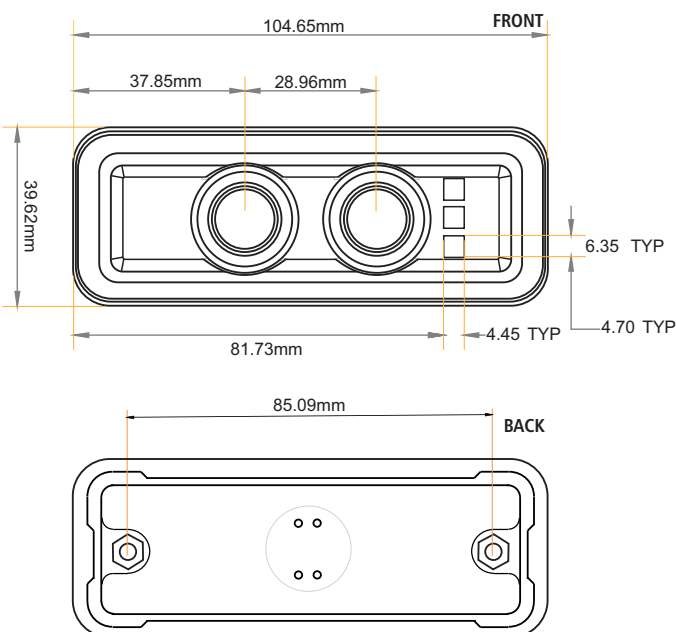

MOUNT ON A FLAT SURFACE ONLY

Part Number:	DSS-PKU1200MI
Nut Size*:	10-32 UNF S/S
Washer Sizes:	M5 Spring Washer S/S, M5 Flat Washer S/S
Torque Maximum:	7 +/- 1 in. lbs

* DO NOT USE NYLOC NUTS

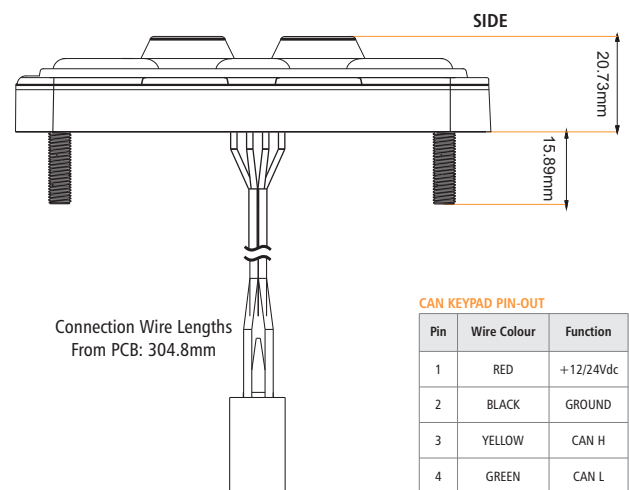

Pin	Wire Colour	Function
1	RED	+12/24Vdc
2	BLACK	GROUND
3	YELLOW	CAN H
4	GREEN	CAN L

* Diagrams are NOT to Scale