

| REVISIONS | | | | |
|-----------|------|-----------------|-----------|-------------|
| ZONE | REV. | DESCRIPTION | DATE | APPROVED |
| | A | INITIAL RELEASE | 6/21/2021 | JAKE JANOSO |

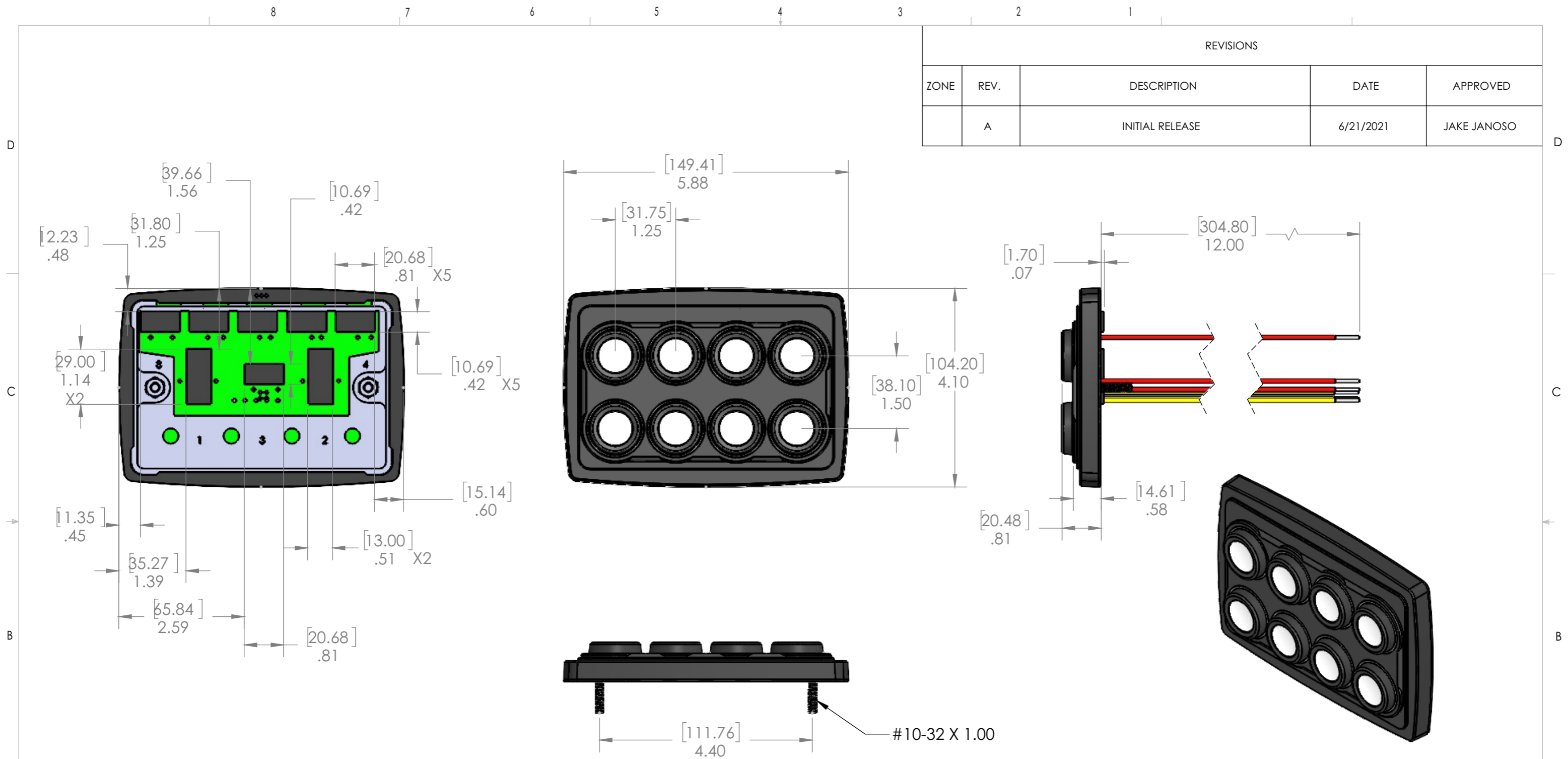

| | | | | | |
|---|---|-----------|----------|-------------------------------------|---|
| REVISION(S) PER ECN #: | UNLESS OTHERWISE SPECIFIED: | NAME | DATE | Digital Switching Systems Australia | |
| ECN DESCRIPTION: | DIMENSIONS ARE IN INCHES [MM] TOLERANCES: FRACTIONAL ± ANGULAR: MACH ± BEND ± TWO PLACE DECIMAL ±0.01 THREE PLACE DECIMAL ±0.005 | DRAWN | JAJ 6/21 | | TITLE: PKR2400 BUTTON SPACING |
| PROPRIETARY AND CONFIDENTIAL THE INFORMATION CONTAINED IN THIS DRAWING IS THE SOLE PROPERTY OF DSSA. ANY REPRODUCTION IN PART OR AS A WHOLE WITHOUT THE WRITTEN PERMISSION OF DSSA IS PROHIBITED. | INTERPRET GEOMETRIC TOLERANCING PER: | CHECKED | | | SIZE DWG. NO. REV B PKR2400 A |
| | MATERIAL | ENG APPR. | | | SCALE: 1:2 WEIGHT: 455g SHEET 1 OF 1 |
| | FINISH | MFG APPR. | | | |
| DO NOT SCALE DRAWING | COMMENTS: | Q.A. | | | |

| REVISIONS | | | |
|-----------|---------------------|-----------|----------|
| REV. | DESCRIPTION | DATE | APPROVED |
| A | INITIAL RELEASE | 2/8/2018 | |
| B | ADDED TEMPLATE NOTE | 7/28/2020 | |

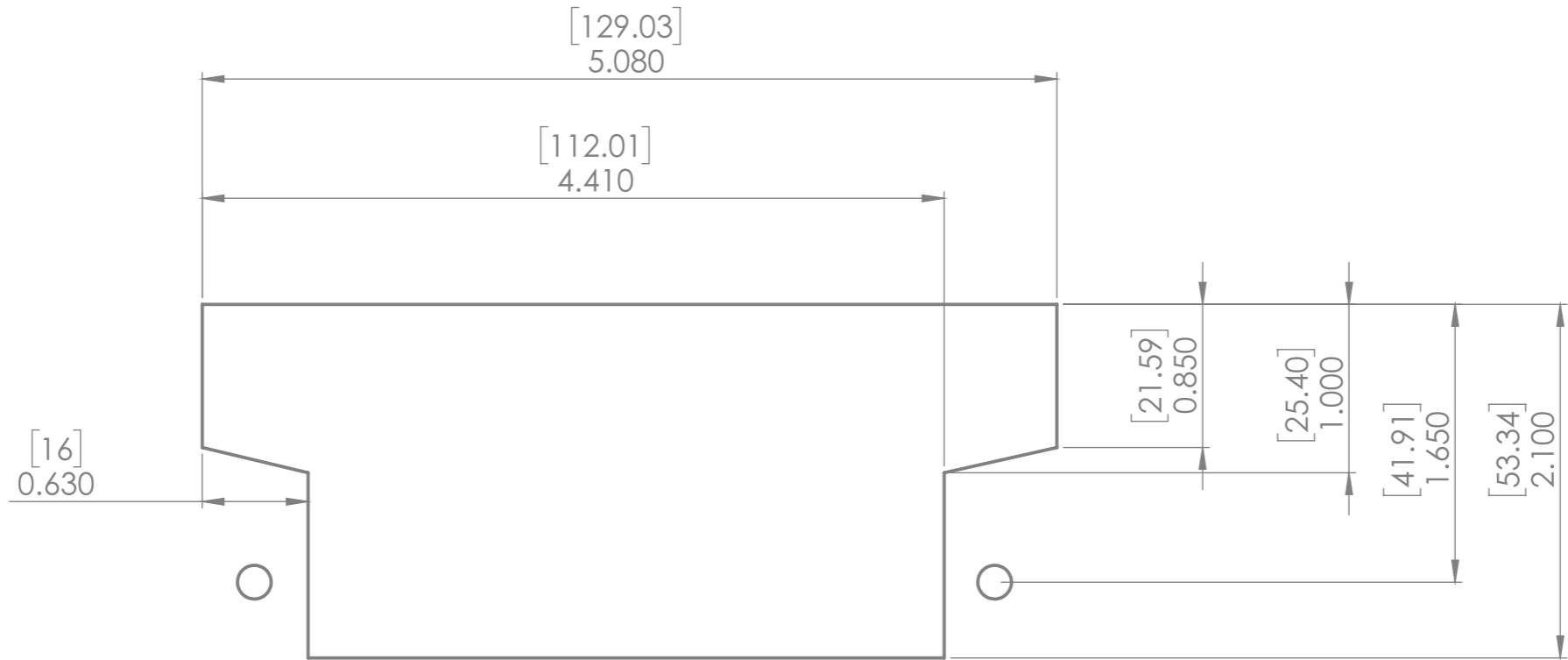

| UNLESS OTHERWISE SPECIFIED: | NAME | DATE |
|--------------------------------------|-----------|------|
| DIMENSIONS ARE IN INCHES | DRAWN | 2/18 |
| TOLERANCES: | CHECKED | |
| FRACTIONAL ± | ENG APPR. | |
| ANGULAR: MACH ±1 BEND ±1 | MFG APPR. | |
| TWO PLACE DECIMAL ±.01 | Q.A. | |
| THREE PLACE DECIMAL ±.005 | COMMENTS: | |
| INTERPRET GEOMETRIC TOLERANCING PER: | | |
| MATERIAL | | |
| FINISH | | |
| DO NOT SCALE DRAWING | | |

| | | |
|-------------------------------------|----------------|--------------|
| Digital Switching Systems Australia | | |
| TITLE: | | |
| PKR2400 CUTOUT | | |
| SIZE | DWG. NO. | REV |
| A | PKR2400 | B |
| SCALE: 1:1 | WEIGHT: 455g | SHEET 1 OF 2 |

PROPRIETARY AND CONFIDENTIAL
THE INFORMATION CONTAINED IN THIS DRAWING IS THE SOLE PROPERTY OF DSSA.



| REVISIONS | | | | |
|-----------|------|-------------|------|----------|
| ZONE | REV. | DESCRIPTION | DATE | APPROVED |
| - | - | See Sheet1 | - | - |



TEMPLATE NOTE: ALL DIMENSIONS ARE 1:1
PLEASE VERIFY SCALING PRIOR TO DRILLING

| UNLESS OTHERWISE SPECIFIED: | NAME | DATE |
|--------------------------------------|-----------|------|
| DIMENSIONS ARE IN INCHES | DRAWN | JRH |
| TOLERANCES: | CHECKED | 5/19 |
| FRACTIONAL ± | ENG APPR. | |
| ANGULAR: MACH ±1 BEND ±1 | MFG APPR. | |
| TWO PLACE DECIMAL ±.01 | Q.A. | |
| THREE PLACE DECIMAL ±.005 | COMMENTS: | |
| INTERPRET GEOMETRIC TOLERANCING PER: | | |
| MATERIAL | | |
| FINISH | | |
| DO NOT SCALE DRAWING | | |

| | | |
|-------------------------------------|----------------|--------------|
| Digital Switching Systems Australia | | |
| TITLE: | | |
| PKR2400 CUTOUT | | |
| SIZE | DWG. NO. | REV |
| A | PKR2400 | B |
| SCALE: 1:1 | WEIGHT: 455g | SHEET 2 OF 2 |

PROPRIETARY AND CONFIDENTIAL
THE INFORMATION CONTAINED IN THIS DRAWING IS THE SOLE PROPERTY OF DSSA



5

4

3

2

1

PKR2400 DIMENSIONS

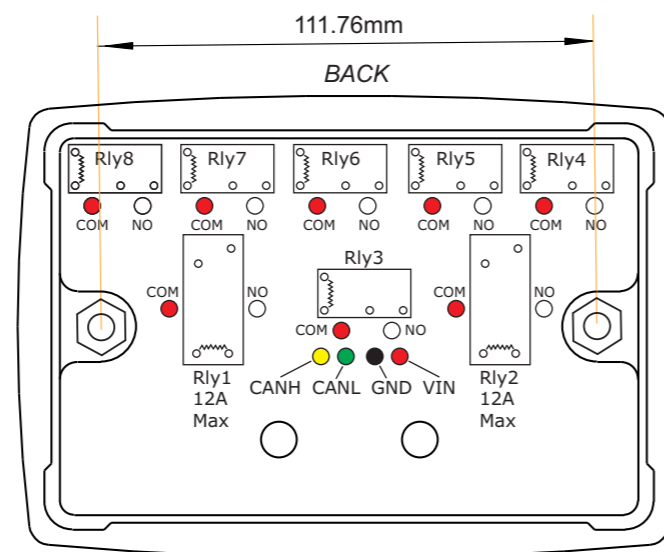
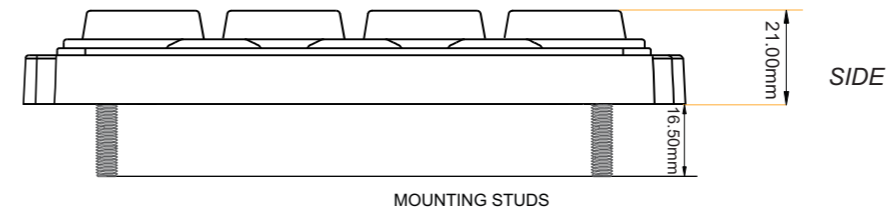
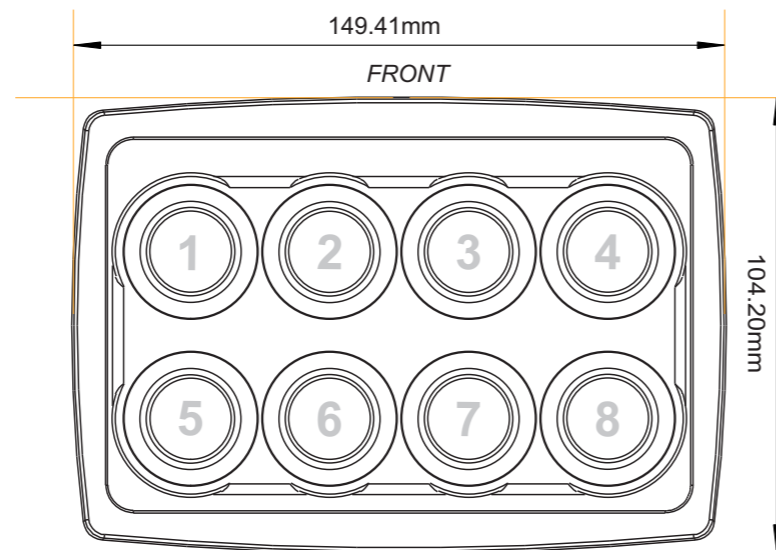

* Diagrams are NOT to Scale

MOUNT ON A FLAT SURFACE ONLY

| | |
|-----------------------|--|
| Part Number: | DSS-PKR2400 |
| Weight: | 455g |
| Nut Size*: | 10-32 UNF S/S |
| Washer Sizes: | M5 Spring Washer S/S, M5 Flat Washer S/S |
| Torque Mounting Nuts: | 7 +/- 1 in. lbs |

* DO NOT USE NYLOC NUTS

