

Combo 64

When Safety Matters



- Beacon Control
- Spare Output
- D.R.L Control
- Park Brake Alarm

Combo 64

The Combo 64 is an advanced safety device aimed to simplify, control and warn a driver in case of a problem.

It utilises the latest digital, micro controller technology to ensure reliability and performance.

It allows for automatic control of preset devices inside the cabin of a vehicle.

Utilising six inputs and four outputs, the Combo 64 can automatically warn a driver that the hand brake is not on, can turn on DRL's as a preset function, turn beacons on and has many more applications.

Overview

The Combo 64 is an advanced safety device aimed to simplify control, and to warn the operator should a safety parameter be breached. It utilises the latest digital micro-controller technology to ensure reliability and performance. These instructions are intended for use by an authorised installer. Modifications, manipulations or improper repairs can affect the operability and safety.

Connection

There are two connection options shown in the wiring diagrams below. In the typical connection, Output 4 Common should be connected to ground, if the accessory requires negative switching.

The Alternative Connection shows the wiring required if the accessory running through Output 4 requires positive switching.

Typical Connection

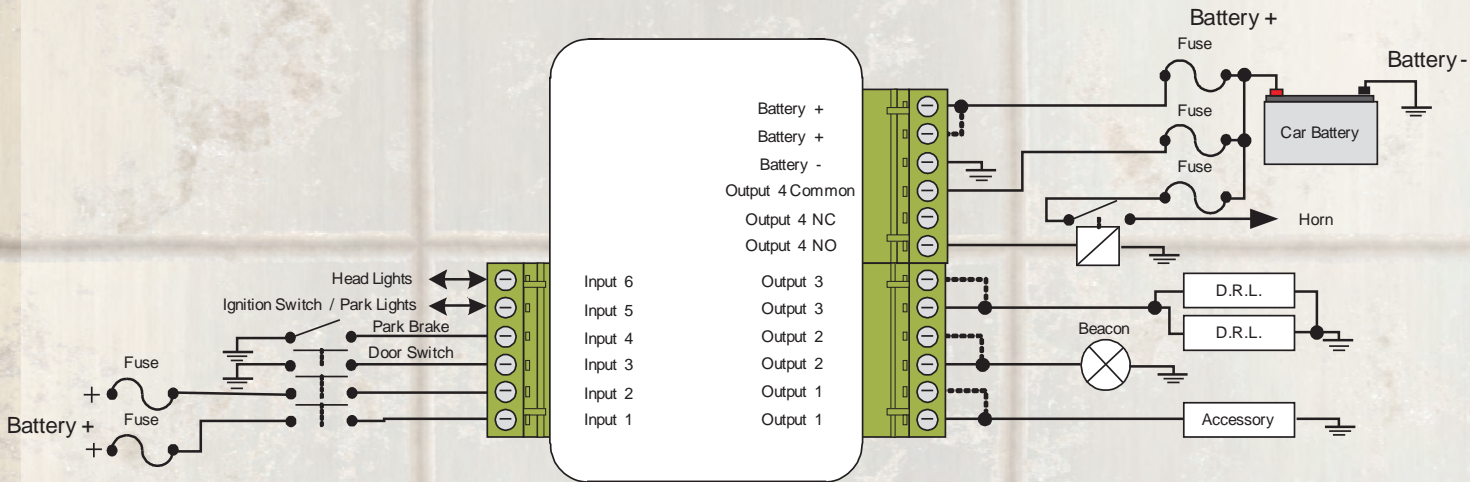

- ⚠ 1. Ensure the polarity of device connected to input /output
- 2. Inputs can be positive or negative switches . Configuration is done via DIP switch settings . Please refer to installation manual .

Typical Connection

Alternative Connection

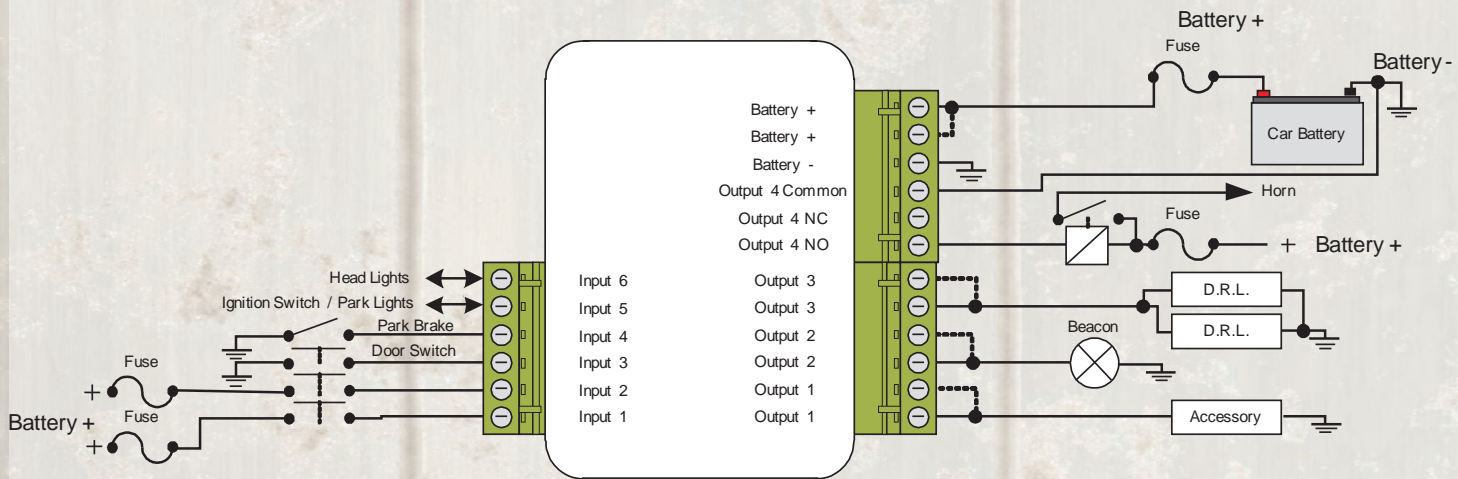

- ⚠ 1. Ensure the polarity of device connected to input /output
- 2. Inputs can be positive or negative switches . Configuration is done via DIP switch settings . Please refer to installation manual .

Alternative Connection (STG Relay)

Installation Guide

Mount the Combo 64 in a dry safe, secure place away from the heat and humidity. If possible, select an inconspicuous area that will not be routinely accessed. Make sure the device is kept clear of moving parts or debris. Also ensure the device is safe from moisture or liquids.

Please ensure you read this complete manual as fitting instructions and testing procedures are incorporated throughout.

Operation Overview

General Input 1 and General Input 2 are momentary inputs, briefly connect the input to battery + or battery negative (depending on the DIP switch setting) to toggle on and off General Output 1 and General Output 2 respectively.

If General Input DIP switch is enabled (ON), releasing the Park Brake will switch OFF General Output 1 and General Output 2.

The Door Switch and Park Brake switches are set to Low Active (by Default) but can be configured either way. If Door Switch is active (Open) while Park Brake is NOT active (OFF), the on board buzzer will immediately sound for 5s before alarm (Output 4) is activated. Applying the Park Brake will disable BOTH buzzer and alarm immediately. Once the door is opened, the alarms latch on unless the park Brake is applied. It is good practice to apply the park brake BEFORE opening the door.

If Daytime Running Light is set to be controlled by Battery Voltage sensing, Day Time Running Light (Output 3) is turned ON with a delay of 5s once the engine is running and the Alternator is charging. If either the Head Light or Park Light is turned ON the DRL's are turned OFF immediately. The DRL's are also turned off with a delay of 20s once the battery voltage falls below the pre set threshold setting.

If Daytime Running Light is set to be controlled by Ignition Switch, Daytime Running Light (Output 3) is turned ON with a delay of 5s once the Ignition Switch is turned ON. If Head Light is turned ON the DRL are turned OFF immediately. The DRL is turned OFF with a delay of 20s once the Ignition Switch is turned OFF.

Note: Disconnect Battery before doing any connection.

Input Configuration

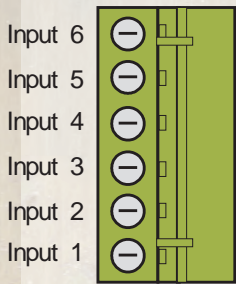

Name	Description	Default Switch Mode	Default Active Mode
Input 1	General Input 1	Momentary STB	High
Input 2	General Input 2	Momentary STB	High
Input 3	Door Switch	STG	Low
Input 4	Park Brake	STG	Low
Input 5	Park Light / Ignition Switch*	STB	High
Input 6	Head Lights	STB	High

* Depends on Daytime Running Light Trigger Setting, Input 5 would be operated as Park Light OR Ignition Switch

STB: Switch to Battery Positive STG: Switch to Ground Negative

Output Configuration

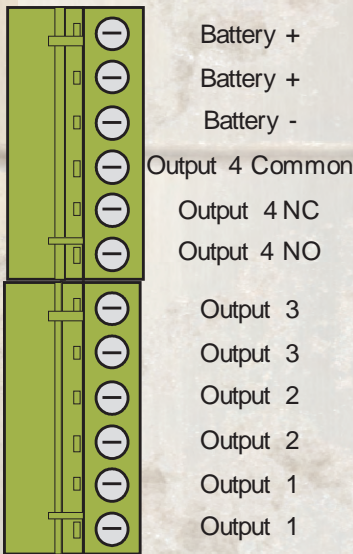

Name	Description	Maximum Fuse
Battery +	Connect to battery +	
Battery +	Connect to battery +	
Battery -	Connect to battery -	
Output 4 Common	Connect to EITHER Battery + OR Battery - for Output 4	5A
Output 4 NC	Mobile Phone (optional)	5A
Output 4 NO	External Alarm	5A
Output 3	Day Time Running Light	10A
Output 2	General Output 2	10A
Output 1	General Output 1	10A

STB: Switch to Battery Positive STG: Switch to Ground Negative

Dip Configuration Access

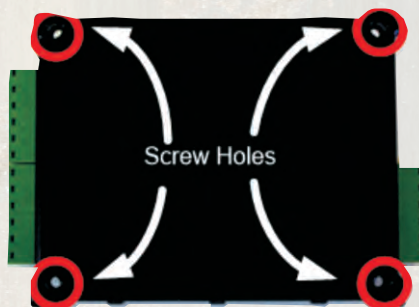
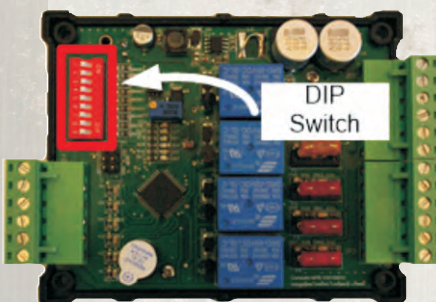

1. Unscrew the four screw holes
2. Remove the cover
3. Change the DIP switch settings
4. Close the cover
5. Screw and secure

Dip Switch Configuration

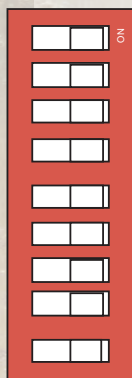

- Voltage
- Daytime Running Light Trigger Setting
- General Input Selection
- General Input 1 Selection
- General Input 2 Selection
- Door Switch Selection
- Park Brake Selection
- Work Light Selection
- Hi Beam Selection

Note: Red LED lights up when the DIP switch is switched to right.

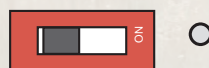

Switch to Left

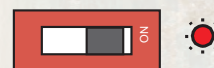

Switch to Right

Name	Description	Switch to Left	Switch to Right
Voltage	+24V/+12V Selection	Select +12V	Select +24V
Daytime Running Light Trigger Setting	Select to control Daytime Running Light using Battery Voltage OR Ignition Switch	Voltage Sense For 24V System: turn on (5s delay) at 27.4V/ turn off (20s delay) at 26.8V For 12V System: turn on (5s delay) at 13.7V/ turn off (20s delay) at 13.4V	Ignition Sense Turn on (5s delay) when Ignition Switch is ON Turn off (20s delay) when Ignition Switch is OFF
General Input Selection	When the Park Brake is Released Switch Off General Output 1/2	Disabled	Enabled
General Input 1 Selection	Select General Input 1 to be Momentary STB or STG	STG (Negative Switching)	STB (Positive Switching)
General Input 2 Selection	Select General Input 2 to be Momentary STB or STG	STG (Negative Switching)	STB (Positive Switching)
Door Switch Selection	Select Door Switch Input to be STB or STG	STG (Negative Switching)	STB (Positive Switching)
Park Brake Selection	Select Park Brake Input to be STB or STG	STG (Negative Switching)	STB (Positive Switching)
Park Light / Ignition Switch Selection*	Select Work Light / Ignition Switch Input to be STB or STG	STG (Negative Switching)	STB (Positive Switching)
Head Lights Selection	Select Head Lights Input to be STB or STG	STG (Negative Switching)	STB (Positive Switching)

* Depends on Daytime Running Light Trigger Setting, Input 5 would be operated as Park Light OR Ignition Switch

Testing Procedure Park Brake Alarm

1. Disconnect Battery before doing any connection.
2. Connect Park Brake switch to Combo 64 Park Brake input.*
3. Connect Door Switch to Combo 64 Door Switch input.
4. Ensure that the polarity of BOTH switch(s), and set the DIP switch setting accordingly.
5. Connect the Battery to the Combo 64.
6. Ensure that the vehicle will not move when the Park Brake is released. Ensure the Park Brake is ON and the driver door is closed.
7. Release the Park Brake, no alarm should be heard.
8. Open driver door, alarm should be heard. Wait 5 seconds to see if the (optional) external alarm is activated.
9. Close driver door, alarm(s) should still be heard.
10. Apply Park Brake, both alarm(s) should stop.

* In case Park Brake Indicator on the dash board lights up after connecting the Park Brake Switch to the Combo 64 Input, installer should install a separate Park Brake Switch for connecting to Combo 64 instead of connecting the original one.

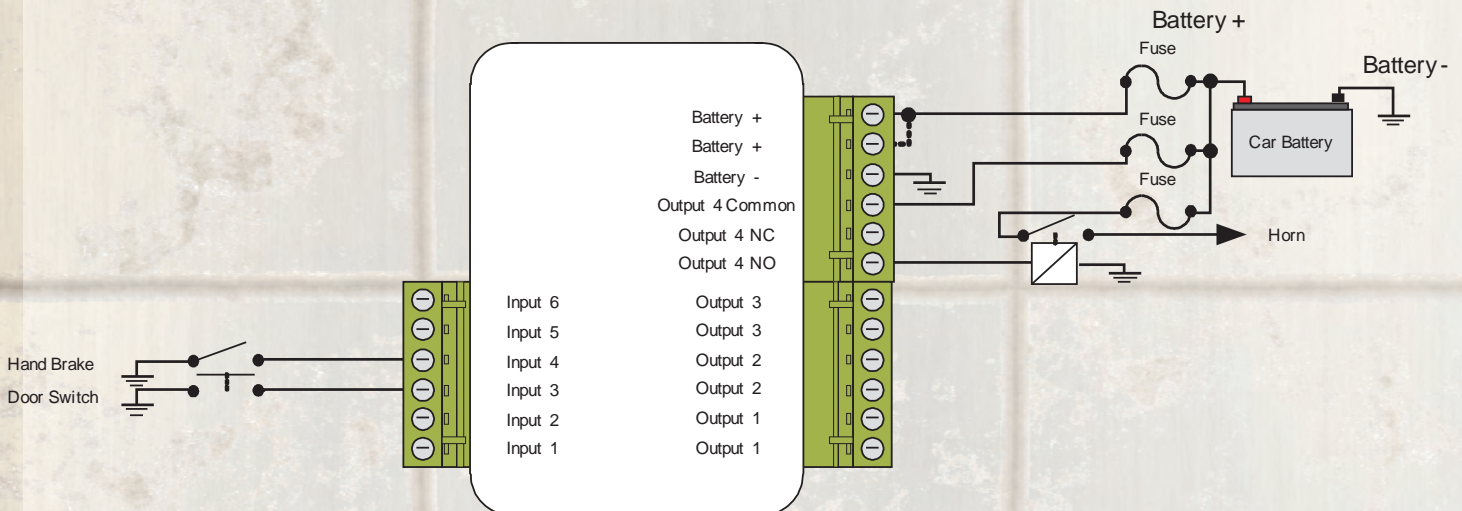

- ⚠ 1. Ensure the polarity of device connected to input /output
 2. Inputs can be positive or negative switches
 Configuration is done via DIP switch settings . Please refer to installation manual .

Typical Park Brake Connection

Testing Procedure Day Time Running Lights

1. Disconnect Battery before doing any connection.
2. Connect Park Light/Ignition to the Combo 64 Park Light/Ignition Inputs respectively.
3. Connect Daytime Running Light to Combo 64 Daytime Running Light output.
4. Ensure that the polarity of Park Brake/Ignition, and set the DIP switch setting accordingly.
5. Ensure the battery voltage is higher than the turn-on threshold. The threshold can be adjusted via the DIP switch setting.
6. Connect the battery to the Combo 64.
7. Switch OFF BOTH Park Light/Head Lights, Daytime Running Light should turn ON after 5 Seconds.
8. Switch on Park Light, Daytime Running Light should turn OFF immediately.
9. Switch off Park Light, Daytime Running Light should turn ON after 5 seconds.
10. Switch on Head Lights, Daytime Running Light should turn OFF immediately.
11. Switch off Head Lights, Daytime Running Light should turn ON after 5 seconds.

For more information on ignition switching see last page.

Testing Procedure Day Time Running Lights

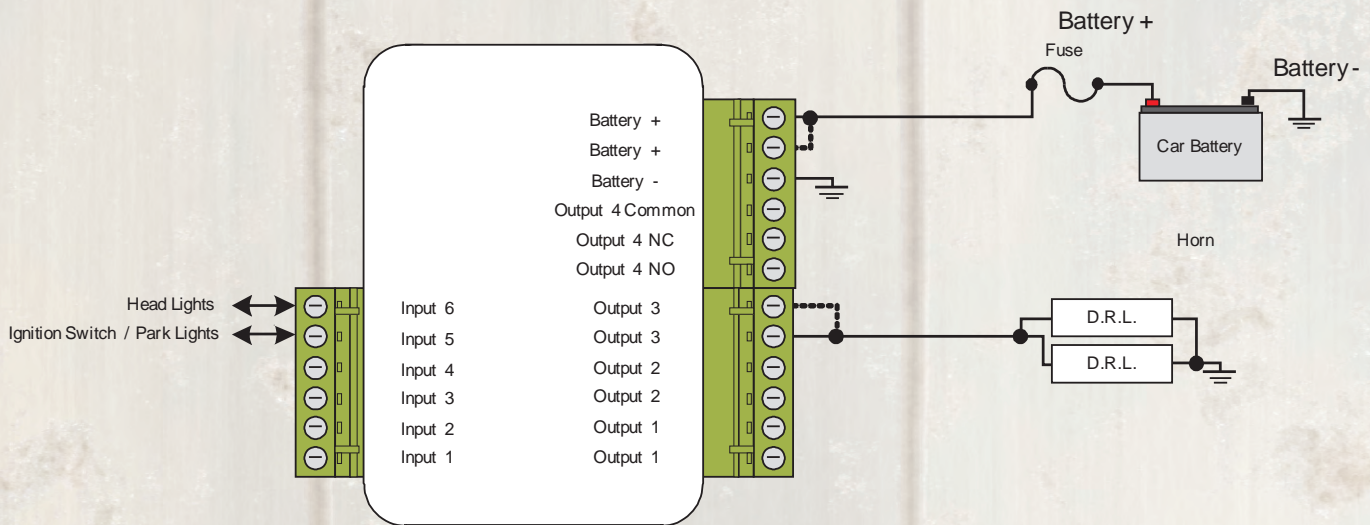

Typical DRL Connection

- 1. Ensure the polarity of device connected to input /output
- 2. Inputs can be positive or negative switches . Configuration is done via DIP switch settings . Please refer to installation manual .

General Input Switch 1 & 2

1. Disconnect Battery before doing any connection.
2. Connect Momentary Switch 1 and 2 to the **Combo 64** General Input 1 and General Input 2 respectively.
3. Connect device to be operated by General Input 1 and General Input 2 to **Combo 64** General Output 1 and General Output 2 respectively.
4. Ensure the polarity of Momentary Switch be Switch to Battery (STB).
5. Connect the Battery to **Combo 64**
6. Press Momentary Switch 1 once, the device connect to General Output 1 will switch ON/OFF status. Press the button again to ensure that it will switch ON/OFF again.
7. Press Momentary Switch 2 once, the device connect to General Output 2 will switch ON/OFF status. Press the button again to ensure that it will switch ON/OFF again.
8. If "General Input Selection" DIP switch setting is enabled, release the Park Brake, BOTH General Output 1 and General Output 2 will switch OFF.

Electrical Parameters

Supply Voltage	+12V to 24V Nominal (+28V Max)
Input Voltage	0V to +24V

For Ignition Setting

1. Disconnect Battery before doing any connection.
2. Connect Ignition Switch to the Combo 64 Ignition Switch input respectively.
3. Connect Daytime Running Light to Combo 64 Daytime Running Light Output.
4. Ensure the polarity Ignition Switch, and set the DIP switch setting accordingly.
5. Connect the Battery to Combo 64.
6. Switch OFF BOTH Park Light/Ignition Switch, Daytime Running Light should turn OFF.
7. Switch ON Ignition Switch, Daytime Running Light should turn ON after 5 seconds.
8. Switch OFF Ignition Switch, Daytime Running Light should turn OFF after 20 Seconds.
9. Switch ON Ignition Switch again, Daytime Running Light should turn ON after 5 seconds.
10. Switch ON Park Light, Daytime Running Light should turn OFF immediately.
11. Switch OFF Park Light, Daytime Running Light should turn ON after 5 seconds.

Mechanical Parameters

Input Connector
Output Connector
Operating Temperature
Storage Temperature
Dimensions (mm)

Phoenix Connector 1 x 6 Pin
Phoenix Connector 2 x 6 Pin
– 20 C to 85 C
– 40 C to 85 C
111.5(L) x 90.5(W) x 32(D)

Trouble Shooting

Problem	Check
No response from Combo 64	<ol style="list-style-type: none">1. Check if the power is good2. Check if the connections are good3. Check if the DIP switch setting is correctly set
No output from Combo 64	<ol style="list-style-type: none">1. Check if the connections are good2. Check if the LED display is correct3. Check if the fuse is broken (indicated by RED LED next to the relay)
Daytime Running Light do not light up	<ol style="list-style-type: none">1. Check if the connections are good2. Check if the battery voltage is greater than the turn-on threshold setting when the engine is running in case voltage setting is used
Daytime Running Light take a long time to switch off	<ol style="list-style-type: none">1. Change to use the Ignition Switch setting